

# FS SERIES

## Soft Closing Full Extension Concealed Slide (with Locking Device)



### Options

- Available with optional elongated holes.
- Optional locking devices available.

### Specification

<b>Function</b>	Soft Closing
<b>Extension</b>	Full Extension
<b>Locking Accessory</b>	Locking Brackets with Metal Chassis
<b>Available Sizes</b>	300 mm - 550 mm
<b>Load Capacity</b>	Up to 30 kg
<b>Thickness</b>	1.0 x 1.5 x 1.8 mm
<b>Material</b>	Galvanized Steel
<b>Packaging</b>	10 Sets per Carton

### Installation Dimensions

SKW = Internal Drawer Width  
 LW = Internal Cabinet Width

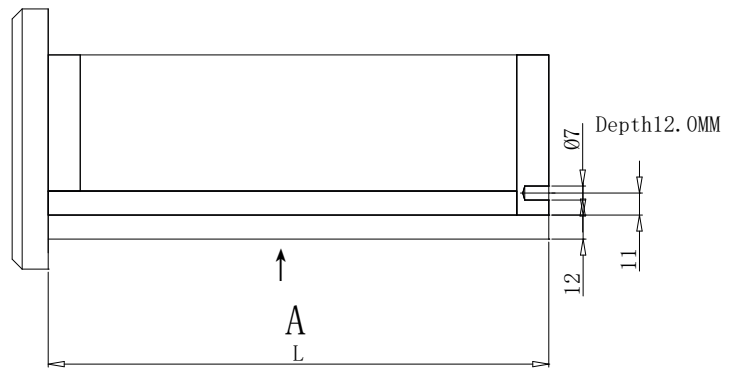
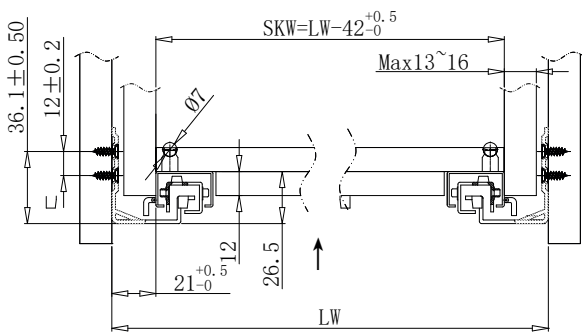

### Drawer Sine and Boring

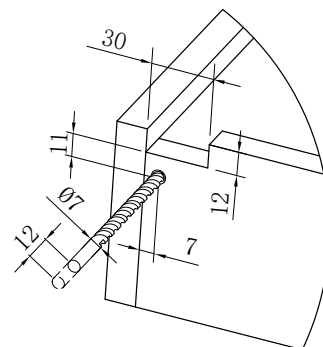
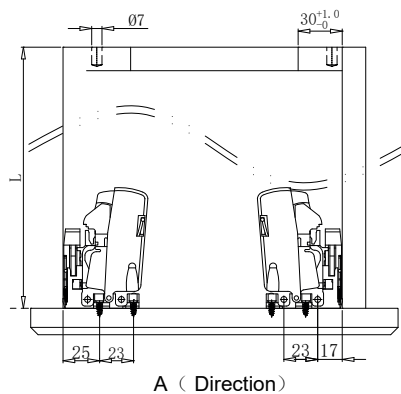

## Slide Mounting Holes

### Hole Pattern

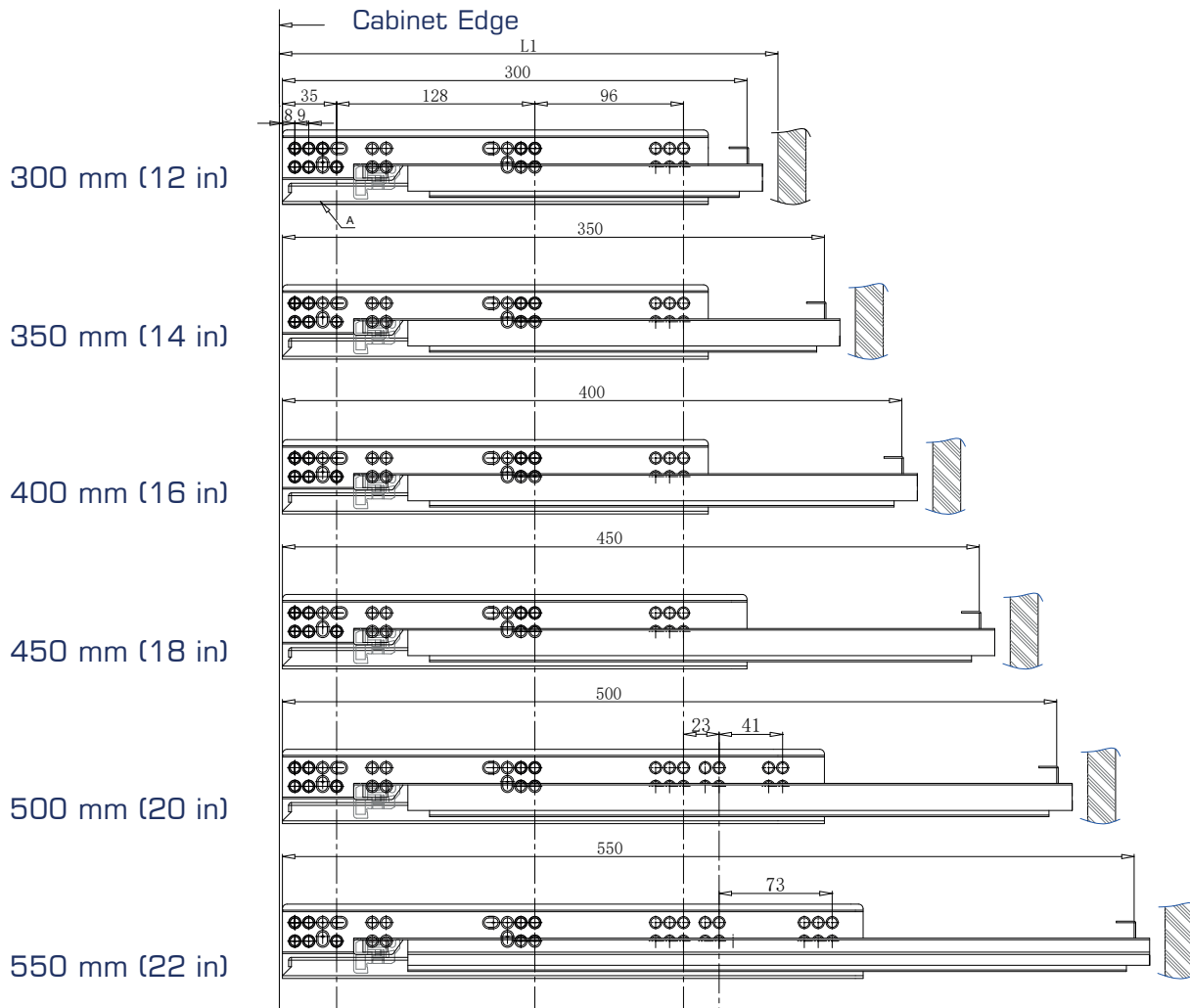

## Measurements Table

Item No	Slide Length (L)		Minimum Cabinet Inner Depth (L1)	Packaging (sets/carton)
FSF0300B	12"	300 mm	319 mm	10
FSF0350B	14"	350 mm	369 mm	10
FSF0400B	16"	400 mm	419 mm	10
FSF0450B	18"	450 mm	469 mm	10
FSF0500B	20"	500 mm	519 mm	10
FSF0550B	22"	550 mm	569 mm	10